



# Solutions for Marine & Offshore

Marine & Offshore



MARKETS &  
APPLICATIONS



# Marine & Offshore



### Winch drives

700C Series  
FW Series

### Slew drives

700T Series  
S Series

### Steering drives

300 Series  
700T Series

### Jack-up drives

700T & JD Series

### Track tensioner drives

700C Series  
F Series

### Multipurpose planetary drives

300 Series

### Helical drives (bevel or parallel shaft)

HDP/HDO Series

## A complete range of drives for Marine and Offshore applications

Bonfiglioli offers a wide range of solutions for lifting, pulling and slewing machinery, like shipboard cranes, offshore cranes, deck machinery, azimuth thrusters and pipelayers.

Thanks to our technical experience and ability to develop flexible and tailor-made solutions, Bonfiglioli is the right partner for all marine and offshore applications.

The design of several groups of products and jacking gears has been approved by major Classification Societies, such as ABS, DNV GL, LR, CCS, RS, etc. These products can be delivered with 3.2 certification and full traceability of the load carrying components.

In addition, we can provide ATEX-certified and special drives developed for low-temperature applications. Bonfiglioli has also developed a specific range of gearboxes for jacking machinery with rack-and-pinion design, intended for jack-up drilling rigs, service lift boats, accommodation and windmill installation vessels.

Bonfiglioli and O&K product series offer one of the largest range of final drives in the world - up to 3.000.000 Nm - to their customers.



# Winch drives



## 700C Series

Planetary winch gearboxes of the 700C series are composed of 18 finely spaced frame sizes. The compact design allows the gearbox to be integrated into the winch drum. The failsafe brake can be integrated inside the gearbox or mounted externally, with common lubrication for the gears. Electrically driven versions are available with both in-line and right-angle configurations. Torque ratings are organized by FEM class, in accordance with minimum approved class safety factors for gears.



HYDRAULIC  
SOLUTIONS



ELECTRIC  
SOLUTIONS



DREDGING  
VESSELS



MERCHANT  
VESSELS



OFFSHORE  
CONSTRUCTION  
VESSELS



OFFSHORE  
PLATFORMS



PIPELAYERS &  
CABLE LAYERS



WORK &  
TUG BOAT

### Input speed

- up to 4,000 rpm

### Applicable motors

- Cartridge axial piston hydraulic motors
- Flanged axial piston hydraulic motors
- Hydraulic orbit motors
- Electrically driven versions are available with both in-line and right-angle configurations

### Key features

- Class approval program
- ATEX conformity on demand
- Torque ratings are organized by FEM class
- The failsafe brake can be integrated inside the gearbox or mounted externally, with common lubrication for the gears

### Torque (Nm)

FEM classification M5-L2-T5 at  
OUTPUT SPEED 25 rpm:

703 C2	2,000
705 C2	5,300
706 C3	10,000
707 C3	16,000
709 C3	23,000
710 C3	29,500
711 C3	31,000
713 C3	48,500
715 C3	64,500
716 C3	77,500
717 C3	105,900
718 C3	111,500
720 C3	164,500
722 C3	260,000



Type	Range of ratios	Max. input speed	Hydraulic motor drive <sup>(1)</sup>	Braking torque	Min. opening pressure	Weight
	1:	RPM		Nm	bar	kg
703 C2	19-40	4000	HS	210	18	42
705 C2	22-53	3500	HS	220 - 310	10 - 20	60
706 C3	68-173	3500	HS	250 - 500	10 - 20	95
707 C3	55-120	3500	HS	250 - 500	10 - 20	135
709 C3	55-147	3500	HS	250 - 600	10 - 20	180
710 C3	55-166	3500	HS	250 - 600	10 - 20	200
711 C3	71-163	3500	HS	400 - 800	10 - 20	270
713 C3	56-147	3000	HS	400 - 800	10 - 20	310
715 C3	62-156	3000	HS	600 - 1000	10 - 20	350
716 C3	83-174	3000	HS	800 - 1200	10 - 20	400
717 C3	92-211	3000	HS	800 - 1200	10 - 20	630
718 C3	87-263	3000	HS	800 - 1400	10 - 20	750
720 C3	175-287	3000	HS	800 - 1700	10 - 20	820
722 C3	296-492	3000	HS	1500 - 2500	15 - 30	1300

(1) LS = Low speed motor / HS = High speed motor

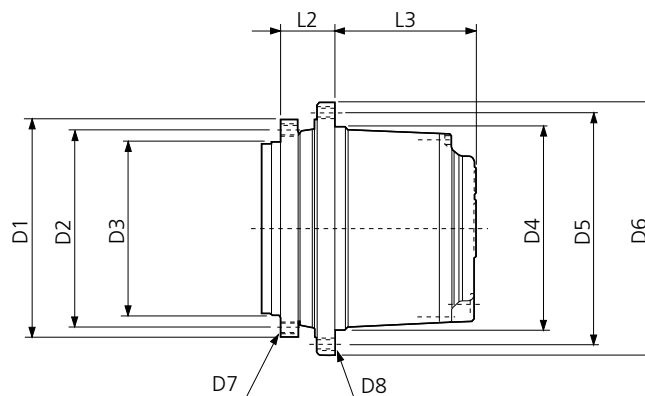

Type	D1	D2	D3	D4	D5	D6	D7	D8	L2	L3
703 C2	270	230	190	200	240	280	M16x2 n.8	M20x1.5 n.8	72	128
705 C2	270	230	190	220	260	300	M16x2 n.12	M16x2 n.16	72	158
706 C3	330	300	270	280	330	370	M16x2 n.18	M16x2 n.18	115	190
707 C3	317	285	240	300	340	370	M20x2.5 n.20	M16x2 n.20	82	233
709 C3	375	340	300	330	370	400	M20x2.5 n.16	M16x2 n.30	91	243
710 C3	375	340	300	350	400	435	M20x2.5 n.16	M20x2.5 n.16	91	243
711 C3	425	325	290	410	455	490	M20x2.5 n.24	M20x2.5 n.24	110	265
713 C3	425	325	290	410	455	490	M20x2.5 n.24	M20x2.5 n.24	110	280
715 C3	500	460	420	460	510	550	M20x2.5 n.24	M20x2.5 n.24	130	315
716 C3	500	460	420	460	500	550	M24x3 n.24	M18x1.5 n.36	165	308
717 C3	570	510	450	560	610	660	M30x3.5 n.20	M24x3 n.24	170	350
718 C3	570	510	450	576	626	670	M24x3 n.30	M24x3 n.20	170	350
720 C3	650	600	460	610	680	735	M30x3.5 n.30	M30x3.5 n.24	170	370
722 C3	735	680	580	660	730	785	M30x3.5 n.30	M30x3.5 n.30	188	430

# Winch drives



## FW Series

The FW Series planetary winch gearboxes are suitable for a large spectrum of winch application thanks to their wide torque range. The compact design allows the gearbox to be integrated into the winch drum. The failsafe brake can be integrated inside the gearbox or mounted externally, with common lubrication with the gears. Electrically driven versions are available with both in-line and right-angle configurations.



HYDRAULIC  
SOLUTIONS



ELECTRIC  
SOLUTIONS



DREDGING  
VESSELS



MERCHANT  
VESSELS



OFFSHORE  
CONSTRUCTION  
VESSELS



OFFSHORE  
PLATFORMS



PIPELAYERS &  
CABLE LAYERS



WORK &  
TUG BOAT

## Applicable motors

- Hydraulic motors
- Hydraulic orbit motors
- IEC electric motors

## Key features

- Compact structure
- Robust layout of planetary gear unit
- Robust taper roller bearings for drum support and cable pull
- Integrated disc-brake
- Easy oil change from the front
- Easy drum mounting
- Wide range of ratios
- Wide range of hydraulic and electric motors
- Input shafts and angular input available
- Interchangeable solutions available



## Torque (Nm)

FEM classification M5-L2-T5 at  
OUTPUT SPEED 25 rpm:

FW10	5,400
FW13	7,250
FW30	17,600
FW40	20,000
FW55	25,400
FW80	42,800
FW100	53,500
FW130	100,000
FW180	112,500
FW220	140,000
FW260	175,000
FW360	210,000
FW440	210,000
FW560	280,000
FW620	330,000
FW700	399,000
FW800	456,000
FW1100	627,000

*Larger sizes on request*

Type	Max. Rope Pull	Output Torque Peak	Range of Ratios
	ton	Nm	1:
FW10	2 ... 4	10,000	35 ... 51
FW13	4 ... 6	13,000	93 ... 229
FW30	6 ... 8	30,000	61 ... 305
FW40	8 ... 10	40,000	61 ... 181
FW55	10 ... 12	55,000	63 ... 185
FW80	12 ... 16	80,000	61 ... 206
FW100	16 ... 24	100,000	77 ... 226
FW130	24 ... 32	130,000	69 ... 206
FW180	32 ... 34	180,000	206 ... 281
FW220	34 ... 40	220,000	97 ... 345
FW260	40 ... 46	260,000	69 ... 345
FW360	46 ... 52	360,000	94 ... 490
FW440	52 ... 54	440,000	352 ... 637
FW560	54 ... 65	560,000	357 ... 739
FW620	65 ... 70	620,000	249 ... 462
FW700	70 ... 76	700,000	377 ... 648
FW800	76 ... 88	800,000	283 ... 298
FW1100	88 ... 104	1,100,000	406

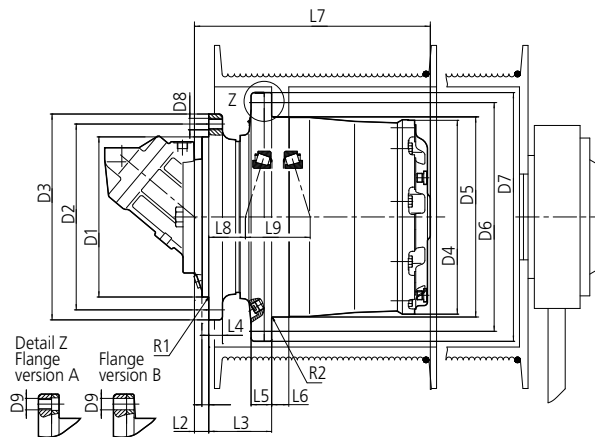

Type	L1	L2	L3	L4	L5	L6	L7	L8	L9	R1	R2	D1	D2	D3	D4	D5	D6	D7	D8	D9 Vers. A	D9 Vers. B	Qty. D8/D9
FW10	10	30	72	13.5	15	16	230	28	79	0.6	0.6	190	230	256	216	220	260	290	M16x2	M16x2	17	12/8
FW13	10	30	72	13.5	15	16	255	28	79	0.6	0.6	190	230	256	216	220	260	290	M16x2	M16x2	17	12/8
FW30	13	25/22	75	15	29	25	323/320	28.5	89	2.5	2.5	240	275	304	269	270	305	335	M16x2	M16x2	17	18/18
FW40	16	16	91	21	34	26	338	38	100	2.5	2.5	240	285	320	294	295	335	370	M16x1.5	M16x1.5	17.5	20/20
FW40A	13	35	91	21	34	26	357	38	100	2.5	2.5	270	310	345	294	295	335	370	M16x1.5	M16x1.5	17.5	16/20
FW55	12	25	110	24	36	30	413	64	113	1	2.5	280	325	360	340	350	400	435	M20x1.5	M20x1.5	22	24/20
FW55A	20	30	91	24	36	30	399	45	113	4	2.5	240	285	320	340	350	400	435	M20x1.5	M20x1.5	22	20/20
FW55B	12	37	110	24	36	30	425	64	113	1	2.5	290	335	370	340	350	400	435	M20x1.5	M20x1.5	22	20/20
FW80	20	35	90	22	37	24	415	34	123	4	2.5	330	370	410	374	400	450	490	M24x2	M24x2	26	20/20
FW100	35/37	35/37	165	28	53	43	461/463	32	139	10 (12)/60	5	390	460	500	407	408	460	500	M24x2	M24x2	26	30/24
FW130	45	45	190	35	58	45	530	50.5	147	25	4	390	500	550	449	450	500	550	M24x2	M24x2	26	32/32
FW180	30	30	168	40	56	21.5	534.5	50.3	141.4	4	3	450	510	560	528	535	600	650	M24x2	M24x2	26	30/30
FW220	18	52	166.5	40	61	35	580.5	16	187.5	35°/16/16	4	460	600	650	540	542	600	650	M24x2	M24x2	26	38/38
FW260	21	45	170	40	48	60	579	18.5	189.5	2	-	460	520	570	608	610	680	735	M30x2	M30x2	32	24/24
FW360	100	100	130	40	60	80	658	-25	215	18°/100/16	10	580	680	735	649	650	720	775	M30x3.5	M30x3.5	32	30/30
FW440	40	43	255	40	25	25	820	80	213	4	4	450	515	569	669	570	620	670	M36x3	M30x3	32	30/30
FW560	40	43	255	45	45	120	831.5	80	213	4	4	450	515	569	763	570	620	670	M36x1.5	M30x1.5	32	29/42
FW620	30	33	405	96	-	306	1159	99	287	4	5	668	726	779	-	782	830	880	M36x1.5	M30x2	32	30/45
FW700	30	33	405	96	-	306	1283.5	99	287	4	5	668	726	779	-	780	850	900	M36x1.5	M36x1.5	38	30/45
FW700A	30	33	405	96	-	306	1372.5	99	287	4	5	668	726	779	-	780	850	900	M36x1.5	M36x1.5	38	30/45
FW800	20	25	229	60	58	170	1315	161/163	257/253	6	8	830	980	1050	916	920	976	1055	M30x2	M30x2	32	48/48
FW1100	57	60	503	74	-	-	1483	176	368	10	6	1110	1230	1310	1116	-	1170	1226	M36x4	M30x3.5	32	48/52

# Slew drives



## 700T Series

Bonfiglioli 700T series slew drives can withstand very high torque ratios while maintaining high efficiency with reduced dimensions and weight. Suitable for the most severe duties in a marine environment, these drives are available with integrated pinion. Their design optimizes torque performance and radial load capacity to give excellent mesh pinion and ring gear. For accurate adjustment, Bonfiglioli series are available with eccentric mounting between the pinion axis and the casing axis.



HYDRAULIC  
SOLUTIONS



ELECTRIC  
SOLUTIONS



MERCHANT  
VESSELS



OFFSHORE  
CONSTRUCTION  
VESSELS



OFFSHORE  
PLATFORMS



PIPELAYERS &  
CABLE LAYERS

### Brake options

- Hydraulically released parking brake on request

### Applicable motors

- Piston hydraulic motors
- Hydraulic orbit motors
- IEC electric motors

### Motors options

- Pressure relief valve
- Overcenter valve

### Key features

- Flange mounted
- Output shaft: splined or with
- Integral pinion
- Rugged construction
- High torque capacity
- Output shafts supported by heavy-duty capacity bearings

### Torque (Nm)

FEM classification M5-L2-T5 at  
OUTPUT SPEED 25 rpm:

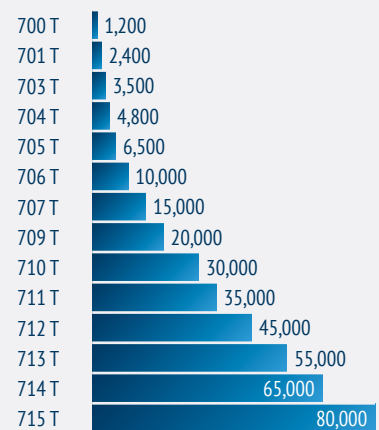



Type	Range of Ratios	Max. Input Speed	Hydraulic Motor Drive*	Braking Torque	Min. Opening Pressure	Design
	max/min	bar		Nm	bar	
700 TF	3.48-7.2	500	LS	50 - 400	10 - 30	A
701 TF	3.48-7.2	500	LS	50 - 400	10 - 30	A
703 TF	12-44	3,000	HS	50 - 400	10 - 30	A
704 TF	12-44	3,000	HS	50 - 400	10 - 30	A
705 TF	12-44	3,000	HS	50 - 400	10 - 30	A
705 TL	12-44	3,000	HS	50 - 400	10 - 30	B
706 TN	15-46	3,000	HS	400 - 1,000	20 - 30	B
707 TN	17-47	3,000	HS	400 - 1,000	20 - 30	B
709 TN	17-47	3,000	HS	400 - 1,000	20 - 30	B
710 TN	19-38	3,000	HS	400 - 1,000	20 - 30	B
711 TC	14-39	3,000	HS	400 - 1,000	20 - 30	B
711 TF	14-39	3,000	HS	400 - 1,000	20 - 30	A
712 TF	80-200	3,000	HS	400 - 1,000	20 - 30	A
712 TN	80-200	3,000	HS	400 - 1,000	20 - 30	B
713 TN	50-300	3,000	HS	400 - 1,000	20 - 30	B
714 TF	90-180	3,000	HS	400 - 1,000	20 - 30	A
715 TN	57-250	3,000	HS	400 - 1,000	20 - 30	B

(\*) LS = Low speed motor / HS = High speed motor

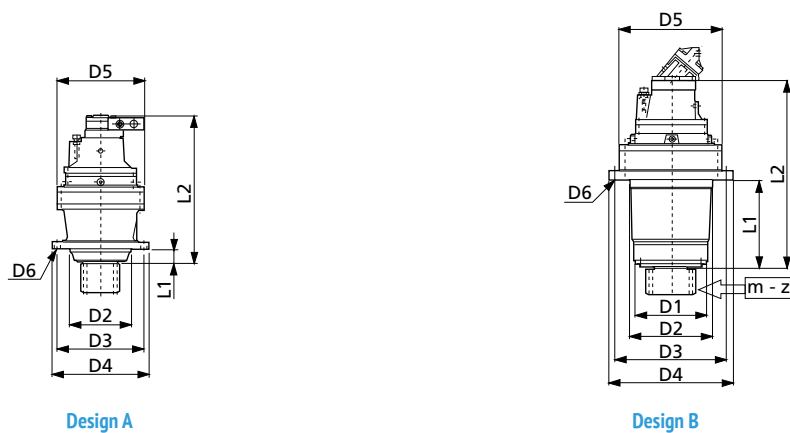

Type	D1	D2	D3	D4	D5	D6	L1	L2	m	z
700 TF	-	150	195	220	186	12.5	31	300		
701 TF	-	150	195	220	186	12.5	31	325		
703 TF	-	175	245	272	245	18	41	410		
704 TF	-	175	245	272	245	18	41	400		
705 TF	-	175	245	272	245	18	41	440		
705 TL	180	195	245	290	245	13	171	470		
706 TN	200	250	325	360	292	17	225	560		
707 TN	230	280	314	348	345	17	295	670		
709 TN	250	280	380	420	345	17	295	720		
710 TN	300	425	460	500	400	22	360	730		
711 TC	300	425	460	500	428	22	345	735		
711 TF	500	320	500	560	425	22	70	750		
712 TF	-	410	450	490	420	ø21 n.24	120	900		
712 TN	400	425	470	510	420	ø20 n.30	350	900		
713 TN	340	400	510	560	445	22	420	1,030		
714 TF	-	420	490	530	490	ø22 n.24	160	1,100		
715 TN	370	470	600	640	542	22	465	1,250		

Pinion module/  
number of teeth  
UPON REQUEST

# Slew drives



## S Series

The Bonfiglioli S series provides the safest and most effective solution for marine and offshore applications. Its compact design makes it the perfect fit for space-limited applications.



HYDRAULIC SOLUTIONS



MERCHANT  
VESSELS



OFFSHORE  
CONSTRUCTION  
VESSELS



OFFSHORE  
PLATFORMS



PIPELAYERS &  
CABLE LAYERS

## Key features

- Compact structure
- High performance
- Notchless ground tooth root
- Integrated disc-brake
- Suitable for various hydraulic motors
- High availability by highest teeth and production quality
- Interchangeable solutions

## Torque (Nm)

FEM classification M5-L2-T5 at  
OUTPUT SPEED 25 rpm:

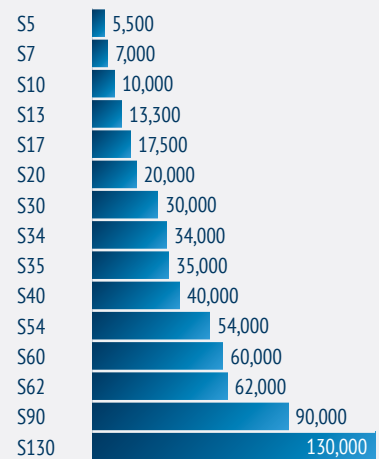

*Stated torques are peak values for short periods of time.*



Type	Ratio <sup>1</sup>	Hydraulic motors <sup>2</sup>	Multi-disc brake		Weight without Motor (appr.)
			Braking torque	Release pressure min.	
	i	ccw	Nm	bar	kg
S5	25-33	28-30-32	310	14	68
S7	23-27-33	45-56-63	475	14	98
S10	24-27-31-36	45-56-63-80-90	475	14	108-123
S13	36	56-63-80-90	740	18	147
S17	33	80-90	890	18	168
S20	103-79	45	553	18	260
S30	45	125	1,030	18	540
S34	45	160	1,030	18	480
S35	35	180	1,030	18	528
S40	62	90	574	18	274
S54	48	180-200	1,200	38	867
S60	62	80	1,200	38	-
S62	187	80	533	18	564
S90	39	355-200	3,000	14	1,225
S130	67	Electric <sup>4</sup>	2,300	22.5	2,276

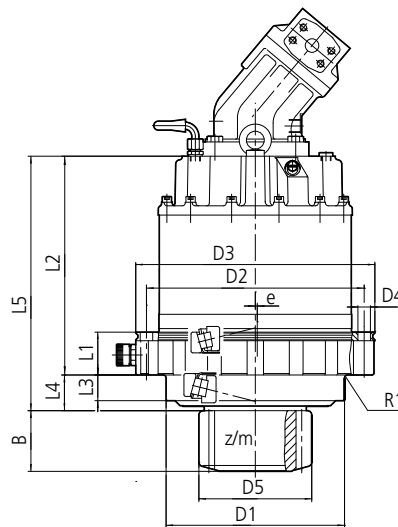

Type	L1	L2	L3	L4	L5	D1	D2	D3	D4	e	R1
S5	60	262	31	40	302	175	260	288	12x17.5	-	6
S7	60	296	31	40.5	336.5	230	285	322	12x17.5	-	6
S10	60	306.5-314	36	50	356.5-364	250	305	335	18x17.5	-	4
S13	71	340	30(50) <sup>3</sup>	55(75) <sup>3</sup>	395(415) <sup>3</sup>	275	335	370	20x17.5	1	4
S17	86	355	50.5	55	410	275	335	370	20x17.5	-	4
S20	57	403	16	252	775	280	350	380	18	-	-
S30	332	737	33	65	802	350	415	450	24x22	-	1.6
S34	332	785	33	65	808	350	415	450	24x22	-	1.6
S35	239	653	<sup>30</sup>	91	744	400	460	500	24x26	2	10
S40	64	625	16	245	721	282	375	410	18	-	-
S54	610	780	40	87	917	460	520	562	24x26	-	-
S60	-	830	40	132	962	460	520	562	26	-	-
S62	60	735	20	28	763	-	-	-	-	-	-
S90	80	730	<sup>173</sup>	199	929	500	640	690	18x30	-	-
S130	578	622	95	160	1012	630	675	715	34x26	-	-

1) Other ratios on request

2) Other hydraulic motors on request

3) Optional

# Steering drives



## 300 Series

The 300 series is compact and powerful. Their planetary drive train makes them the ideal choice for all severe duty applications where shock loads and impacts are more the rule than the exception. The product configuration is highly versatile, due to several options for mounting, gear layout, output shaft and motor interface. All the features are available for each of the 10 finely spaced frame sizes.



HYDRAULIC  
SOLUTIONS



ELECTRIC  
SOLUTIONS



MERCHANT  
VESSELS



OFFSHORE  
CONSTRUCTION  
VESSELS



OFFSHORE  
PLATFORMS



WORK &  
TUG BOAT



PIPELAYERS &  
CABLE LAYERS

### Gear ratios

- 3.4 ... 5,000

### Brake options

- Hydraulically released parking brake on request
- DC and AC type

### Output

- Foot and flange mounted
- Output shaft: solid with key, splined, splined hollow, hollow with shrink disc

### Input



- Flanged axial piston hydraulic motors
- Hydraulic orbit motors
- IEC and Nema motor adapters
- Solid input shaft

### Applicable motors

- Piston hydraulic motors
- Hydraulic orbit motors
- IEC electric motors

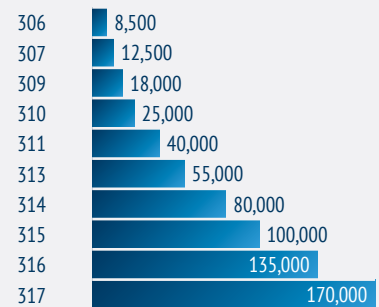
### Torque (Nm)



Type	Max power	Max input speed			Design
	kW	RPM	Inline	Right angle	
306	75	2,500	3.6 - 2,900	9 - 800	A
307	100	2,500	3.4 - 2,400	13 - 700	A
309	130	2,500	3.4 - 2,400	13 - 700	B
310	150	2,000	4 - 2,500	40 - 900	B
311	180	2,000	4 - 2,100	18 - 800	B
313	200	2,000	4 - 2,200	18 - 800	B
314	225	2,000	4 - 1,800	50 - 600	B
315	250	1,500	4 - 1,800	70 - 900	B
316	270	1,500	4.4 - 1,200	50 - 600	B
317	300	1,000	4 - 1,900	70 - 900	B

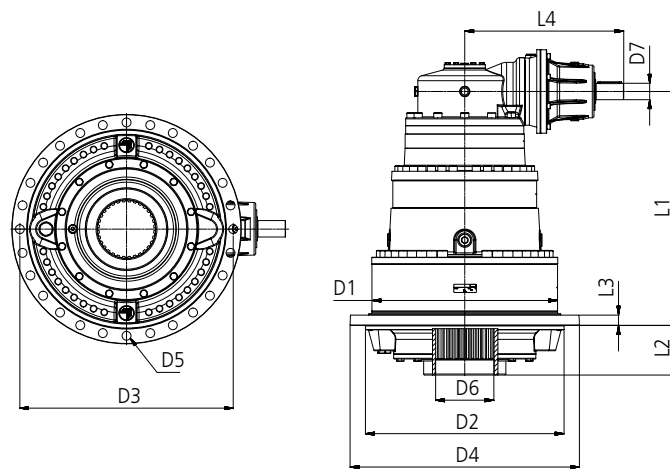

Type	L1	L2	L3	L4	D1	D2	D3	D4	D5	D6	D7
306	370	40	20	280	292	200	250	280	15	70x64 DIN 5482	38
307	411	36	24	280	348	230	295	325	17	80x74 DIN 5482	38
309	345	82	117	280	348	278	314	348	17	80x74 DIN 5482	38
310	381	95	110	298	400	340	370	400	17	100x94 DIN 5482	38
311	429	88	134	298	428	358	390	428	17	120x3 DIN 5480	38
313	485	81	169	298	445	385	415	445	17	140x5 DIN 5480	38
314	635	98	192	298	542	460	503	542	21	150x5 DIN 5480	38
315	638	98	192	464	542	460	503	542	21	150x5 DIN 5480	48
316	683	145	30	464	670	580	625	542	22	170x5 DIN 5480	48
317	740	152	200	464	695	560	635	695	32	200x5 DIN 5480	48

# Steering drives



## 700T Series

Bonfiglioli 700T series slew drives can withstand very high torque ratios while maintaining high efficiency with reduced dimensions and weight. Suitable for the most severe duties in a marine environment, these drives are available with integrated pinion. Their design optimizes torque performance and radial load capacity to give excellent mesh pinion and ring gear. For accurate adjustment, Bonfiglioli series are available with eccentric mounting between the pinion axis and the casing axis.



HYDRAULIC  
SOLUTIONS



ELECTRIC  
SOLUTIONS



MERCHANT  
VESSELS



OFFSHORE  
CONSTRUCTION  
VESSELS



OFFSHORE  
PLATFORMS



WORK &  
TUG BOAT



PIPELAYERS &  
CABLE LAYERS

### Brake options

- Hydraulically released parking brake on request

### Applicable motors

- Piston hydraulic motors
- Hydraulic orbit motors
- IEC electric motors

### Motors options

- Pressure relief valve
- Overcenter valve

### Key features

- Flange mounted
- Output shaft: splined or with
- Integral pinion
- Rugged construction
- High torque capacity
- Output shafts supported by heavy-duty capacity bearings

### Torque (Nm)

706 T	10,000
707 T	15,000
709 T	20,000
710 T	30,000
711 T	35,000
712 T	45,000
713 T	55,000
714 T	65,000
715 T	80,000



Type	Range of Ratios	Max. Input Speed	Hydraulic Motor Drive*	Braking Torque	Min. Opening Pressure
	max/min	bar		Nm	bar
706 T	15-46	3,000	HS	400 - 1,000	20 - 30
707 T	17-47	3,000	HS	400 - 1,000	20 - 30
709 T	17-47	3,000	HS	400 - 1,000	20 - 30
710 T	19-38	3,000	HS	400 - 1,000	20 - 30
711 T	14-39	3,000	HS	400 - 1,000	20 - 30
712 T	80-200	3,000	HS	400 - 1,000	20 - 30
713 T	50-300	3,000	HS	400 - 1,000	20 - 30
714 T	90-180	3,000	HS	400 - 1,000	20 - 30
715 T	57-250	3,000	HS	400 - 1,000	20 - 30

(\* ) LS = Low speed motor / HS = High speed motor

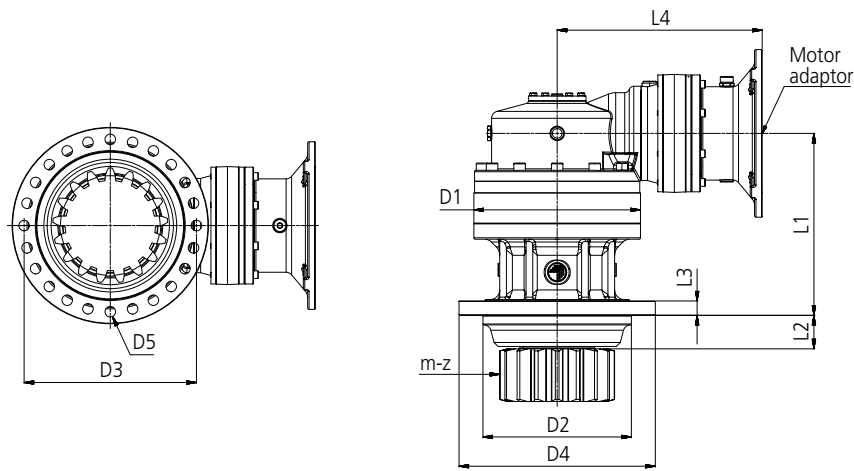

Type	L1	L2	L3	L4	D1	D2	D3	D4	D5	m	z
706 T	Based on the stage number	40	20	Based on the motor adaptor	292	200	230	280	17	Pinion module/ number of teeth UPON REQUEST	
707 T		50	25		348	230	380	420	17		
709 T		50	25		348	250	380	420	17		
710 T		70	30		400	-	-	425	22		
711 T		70	30		428	320	500	560	22		
712 T		120	35		445	410	450	490	21		
713 T		120	35		445	-	-	-	22		
714 T		160	40		490	420	490	530	22		
715 T		160	40		542	510	600	640	22		

# Jack-up drives



## 700T & JD Series

With these planetary gearboxes, Bonfiglioli offers the opportunity for operating the rack to raise and lower the entire hull. Units can be in-line or with a bevel gearbox to facilitate installation of the motor. They can be operated electrically or hydraulically, with or without a negative parking brake. They can be completed with output, with integrated torque arm for easy installation on the machine and with integrated pinion shaft with 50 or 100 toothing module, and large capacity bearing.



HYDRAULIC  
SOLUTIONS



ELECTRIC  
SOLUTIONS



OFFSHORE  
PLATFORMS

### Applicable motors

- Piston hydraulic motors
- IEC electric motors

### Key benefits

- Parking brakes
- Integrated pinions from m50 to m100
- Integrated torque arm

### Max jacking (Nm)

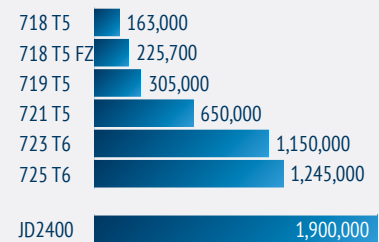



Type	Kips	Max holding		Storm holding
		Nm		Nm
718 T5	200	263,000		350,000
718 T5 FZ	250	263,000		394,500
719 T5	300	450,000		649,000
721 T5 FZ	400	780,000		1,000,000
723 T6 FZ	700	1,430,000		2,050,000
725 T6 FZ	800	1,600,000		2,350,000
JD2400	1,230	up to 2,400,000		up to 2,900,000

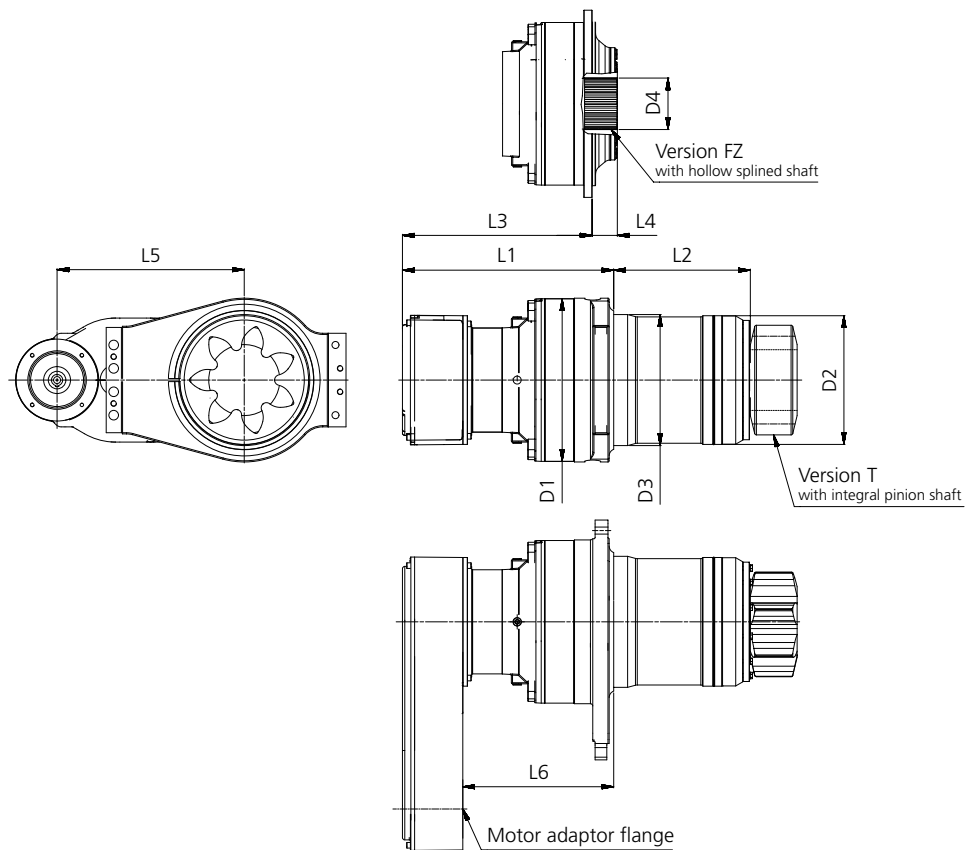

Type	L1	L2	L3	L4	L5	L6	D1	D2	D3	D4
718 T5	930	556	-	-	800	673	695	550	560	-
718 T5 FZ	-	-	810	108	-	-	695	-	-	220x5 DIN 5480
719 T5	986	606	-	-	950	652	790	653	665	-
721 T5 FZ	-	-	1334	-	-	-	940	-	940	300x8 DIN 5480
723 T6 FZ	1272	-	-	330	1100	924	1100	-	960	380x8 DIN 5480
725 T6 FZ	1390	-	-	290	1100	1039	1280	-	990	400x8 DIN 5480
JD2400	1291	1017	842	438	1200	701	1230	1015	1260	480x8 DIN 5480

# Track tensioner drives



## 700C Series

The 700C series track tensioner gearboxes are composed of 9 finely spaced frame sizes. The compact design allows the gearbox to be integrated into the winch drum. The failsafe brake can be integrated inside the gearbox or mounted externally, with common lubrication for the gears. Electrically driven versions are available with both in-line and right-angle configurations. Torque ratings are organized by FEM class, in accordance with minimum approved class safety factors for gears.



HYDRAULIC  
SOLUTIONS



ELECTRIC  
SOLUTIONS



PIPELAYERS &  
CABLE LAYERS

### Input speed

- up to 4,000 rpm

### Applicable motors

- Cartridge axial piston hydraulic motors
- Flanged axial piston hydraulic motors
- Hydraulic orbit motors
- Electrically driven versions are available with both in-line and right-angle configurations

### Key features

- Class approval program
- ATEX conformity on demand
- Torque ratings are organized by FEM class
- The failsafe brake can be integrated inside the gearbox or mounted externally, with common lubrication for the gears

### Torque (Nm)

710 C3 B	36,000
711 C3 B	45,000
713 C3 B	60,000
715 C3 B	85,000
716 C3 B	100,000
717 C3 H	130,000
718 C3 H	180,000
720 C3 H	220,000
722 C3 H	330,000



Type	Range of ratios	Max. input speed	Hydraulic motor drive <sup>(1)</sup>	Braking torque	Min. opening pressure	Weight
	1:	RPM		Nm	bar	kg
710 C3 B	55-166	3500	HS	250 - 600	10 - 20	200
711 C3 B	71-163	3500	HS	400 - 800	10 - 20	270
713 C3 B	56-147	3000	HS	400 - 800	10 - 20	310
715 C3 B	62-156	3000	HS	600 - 1000	10 - 20	350
716 C3 B	83-174	3000	HS	800 - 1200	10 - 20	400
717 C3 H	92-211	3000	HS	800 - 1200	10 - 20	630
718 C3 H	87-263	3000	HS	800 - 1400	10 - 20	750
720 C3 H	175-287	3000	HS	800 - 1700	10 - 20	820
722 C3 H	296-492	3000	HS	1500 - 2500	15 - 30	1300

(1) LS = Low speed motor / HS = High speed motor

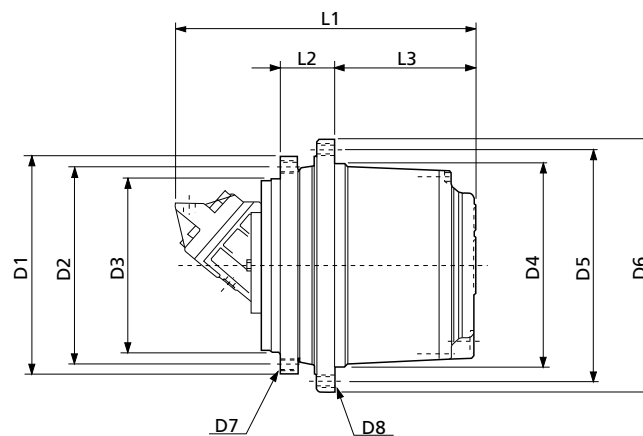

Type	D1	D2	D3	D4	D5	D6	D7	D8	L1	L2	L3	L4
710 C3 B	375	340	300	350	400	435	M20x2.5 n.16	M20x2.5 n.16	Based on the motor type	91	243	-
711 C3 B	425	325	290	410	455	490	M20x2.5 n.24	M20x2.5 n.24		110	265	-
713 C3 B	425	325	290	410	455	490	M20x2.5 n.24	M20x2.5 n.24		110	280	-
715 C3 B	500	460	420	460	510	550	M20x2.5 n.24	M20x2.5 n.24		130	315	-
716 C3 B	500	460	420	460	500	550	M24x3 n.24	M18x1.5 n.36		165	308	-
717 C3 H	570	510	450	560	610	660	M30x3.5 n.20	M24x3 n.24		170	350	-
718 C3 H	570	510	450	576	626	670	M24x3 n.30	M24x3 n.20		170	350	-
720 C3 H	650	600	460	610	680	735	M30x3.5 n.30	M30x3.5 n.24		170	370	-
722 C3 H	735	680	580	660	730	785	M30x3.5 n.30	M30x3.5 n.30		188	430	-

# Track tensioner drives



## F Series

The FW Series track tensioner gearboxes are suitable for a large spectrum of winch applications thanks to their wide torque range. The compact design allows the gearbox to be integrated into the winch drum. The failsafe brake can be integrated inside the gearbox or mounted externally, with common lubrication with the gears. Electrically driven versions are available with both in-line and right-angle configurations.



HYDRAULIC  
SOLUTIONS



ELECTRIC  
SOLUTIONS



PIPELAYERS &  
CABLE LAYERS

## Gear ratios

- 14 ... 1,784

## Standard features

- Compact structure
- High performance
- 3-7 planetary wheels per stage
- Notchless ground tooth root
- Different ratios
- Integrated disc-brake
- Different hydraulic motors
- High availability by highest teeth and production quality

## Special executions on request

- Mechanical disconnect device



## Torque (kNm)

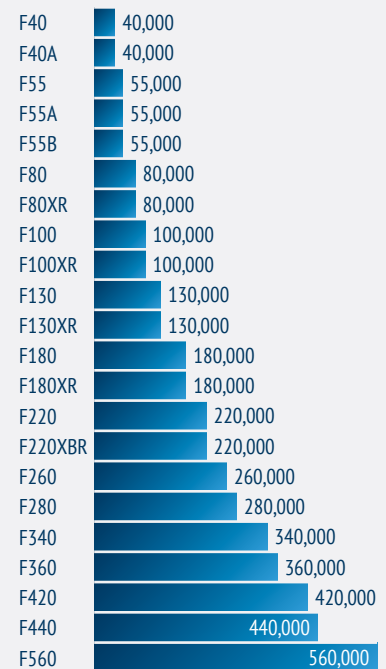

*Stated torques are peak values for short periods of time.*

Type	Ratio <sup>1</sup>	Bearing capacity		Weight <sup>3</sup>	Park Brake		Hydraulic Motor	
		C-dynamic	Co-static		Locking torque	Release pressure min.	Plug-in fixed	Plug-in variable
	i	kN	kN	kg	Nm	bar	ccm	ccm
F40	61 ... 181	224	405	115	420	18	40-45-56-60-63	55-60
F40A		224	405	123	420	18	80-90	80
F55	63 ... 185	224	405	165	420 (390; 500) <sup>2</sup>	15 (15; 21) <sup>2</sup>	80-90	80
F55A		224	405	177	420 (390; 500) <sup>2</sup>	15 (15; 21) <sup>2</sup>	40-45-56-60-63	55-60
F55B		224	405	181	420 (390; 500) <sup>2</sup>	15 (15; 21) <sup>2</sup>	-	107-110
F80	61 ... 206	300	570	230	600 (375; 550; 1000) <sup>2</sup>	18 (18; 19; 28) <sup>2</sup>	80-90-107-110-125-160-180	80-107-110-160
F80XR		300	570	240	600	18	80-90-107-110-160-180	
F100	77 ... 226	498	1,010	330	600 (900) <sup>2</sup>	15 (13) <sup>2</sup>	107-125-160-180	107-110-160
F100XR		498	1,010	341	600	15		
F130	69 ... 206	523	980	452	750	19	107-125-160-180	107-160
F130XR	81 ... 206	-	-	465	750	19		
F180	206 ... 281	787	1,650	636	1375 (800) <sup>2</sup>	35 (35) <sup>2</sup>	160-180	160
F180XR		-	-	-	-	-	-	-
F220	97 ... 345	765	1,660	740	1,200	15	107-180	160-200-215-250-280
F220XBR		-	-	800				
F260	97 ... 345	750	1,560	865	1,000	15	-	355-250
F280	201	1,180	2,600	1,037	1,650	15	-	250
F340	257	1,040	2,450	976	1,700	12	-	-
F360	94 ... 490	1,040	2,450	1,080	1,700	12	355	355
F420	259	1,120	2,555	1,500	1,000	18	-	(2x) 160
F440	352 ... 637	1,040	2,450	1,300	1700 (1000)*	15 (7.8)*	-	250-160
F560	357 ... 739	1,040	2,450	2,000	900	13	-	160

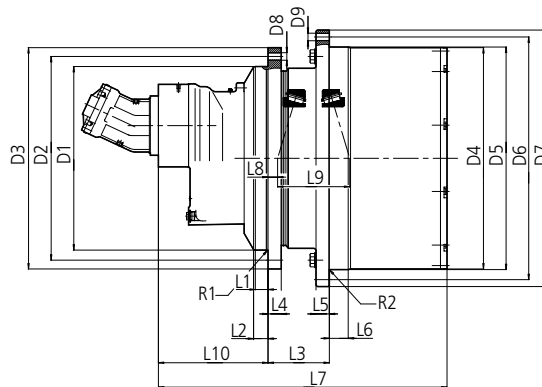

Type	L1	L2	L3	L4	L5	L6	L7	L8	L9	L10	L11	L12	R1	R2	D1	D2	D3	D4	D5	D6	D7	D8	D9	Qty. D8/D9
F40	16	16	91	21	34	26	338	38	100	-	-	-	2.5	2.5	240	285	320	294	295	335	370	M20x1.5	M20x1.5	20/20
F40A	13	35	91	21	34	26	357	38	100	-	-	-	2.5	2.5	270	310	345	294	295	335	370	M20x1.5	M20x1.5	16/20
F55	12	25	110	24	36	30	413	64	113	-	-	-	1	2.5	280	325	360	340	350	400	435	M20x1.5	M20x1.5	24/20
F55A	20	30	91	24	36	30	399	45	113	-	-	-	4	2.5	240	285	320	340	350	40	435	M20x1.5	M20x1.5	20/20
F55B	12	37	110	24	36	30	425	64	113	-	-	-	1	2.5	290	335	370	340	350	400	435	M20x1.5	M20x1.5	20/20
F80	20	35	90	22	37	24	415	34	123	-	-	-	4	2.5	330	370	410	374	400	450	490	M24x2	M24x2	20/20
F80XR	20	35	90	22	37	23	414.5	68.5	123	-	-	-	4	2.5	330	370	410	374	400	450	490	M20x1.5	M20x1.5	20/20
F100	35/37 35/37	165	28	53	43	461/463	32	139	-	-	-	-	10 (12)/60	5	390	460	500	407	408	460	500	M24x2	M24x2	30/24
F100XR	22	35	148	29	53	30	463	32	139	-	-	-	2.5	2.5	380	430	480	407	430	480	500	M24x3	M24x3	20/20
F130	45	45	190	35	58	45	530	50.5	147	-	-	-	25	4	390	500	550	449	450	500	540	M24x2	M24x2	32/32
F130XR	20	70	165	35	58	45	532	25	147	-	-	-	1.2	1.2	420	460	500	449	460	500	540	M24x3	M18x1.5	24/36
F180	30	30	168	40	56	21.5	534.5	50.3	141.4	-	-	-	4	3	450	510	560	528	535	600	650	M24x2	M27x2	30/30
F180XR	30	30	168	40	56	21.5	534.5	50.3	141.4	-	-	-	4	3	450	510	560	528	535	600	650	M24x2	M24x2	30/30
F220	18	52	166.5	40	61	35	580.5	16	187.5	-	-	-	35°/16°/16	4	460	600	650	540	542	600	650	M24x2	M24x2	38/38
F220XBR	52	52	170	40	40	50	580.5	16	187.5	-	-	-	2.5	-	460	600	650	538	610	680	735	M30x3.5	M30x3.5	30/24
F260	21	45	170	40	48	60	579	18.5	189.5	-	-	-	2	-	460	520	570	608	610	680	735	M30x2	33	24/24
F280	52	125	125	40	65	45	627	89.3	180.4	-	-	-	18°/50°/5	4	530	630	685	608	610	685	740	M30x3.5	M30x3.5	28/28
F340	100	100	130	40	60	80	697.5	75	214.8	-	-	-	18°/100°/16	10	580	680	735	649.5	650	720	775	M30x3.5	M30x3.5	30/30
F360	100	100	130	40	60	80	658	25	215	-	-	-	18°/100°/16	10	680	735	649	650	720	775	M30x3.5	M30x3.5	30/30	
F420	60	132	130	40	60	80	1026	43.5	210.7	-	-	-	10	10	660	744	795	670	674	744	795	M30x2	M30x2	42/42
F440	40	43	255	40	25	25	820	80	213	-	40	70	4	4	450	515	569	669	570	620	670	M36x3	M30x3	30/30
F560	40	43	255	45	45	120	831.5	80	213	-	45	70	4	4	450	515	569	763	570	620	670	M36x1.5	M30x1.5	29/42

\*Park brake integrated in hydraulic motor

1) Other ratios on request

2) Optional brake torques

3) Without hydraulic motor

# Multipurpose planetary drives



## 300 Series

The 300 series is compact and powerful. Their planetary drive train makes them the ideal choice for all severe duty applications where shock loads and impacts are more the rule than the exception. The product configuration is highly versatile, due to several options for mounting, gear layout, output shaft and motor interface. All the features are available for each of the 20 finely spaced frame sizes, with a torque range comprised between 1,000 and 1,100,000 Nm.



HYDRAULIC  
SOLUTIONS



ELECTRIC  
SOLUTIONS



DREDGING  
VESSELS



MERCHANT  
VESSELS



OFFSHORE  
CONSTRUCTION  
VESSELS



OFFSHORE  
PLATFORMS



PIPELAYERS &  
CABLE LAYERS



WORK &  
TUG BOAT

### Gear ratios

- 3.4 ... 5,000

### Brake options

- Hydraulically released parking brake on request

### Output

- Foot and flange mounted
- Output shaft: solid with key, splined, splined hollow, hollow with shrink disc

### Input

- Flanged axial piston hydraulic motors
- Hydraulic orbit motors
- IEC and Nema motor adapters
- Solid input shaft



### Applicable motors

- Piston hydraulic motors
- Hydraulic orbit motors
- IEC electric motors

### Torque (Nm)

300	1,000
301	1,750
303	2,500
304	3,600
305	5,000
306	8,500
307	12,500
309	18,000
310	25,000
311	40,000
313	55,000
314	80,000
315	100,000
316	134,000
317	170,000
318	250,000
319	350,000
321	500,000
323	800,000
325	1,100,000



Type	Max power	Max input speed	 		Design
			Inline	Right angle	
300	20	3,000	3.4 - 2,700	7 - 700	A
301	30	3,000	3.4 - 2,700	7 - 700	A
303	40	3,000	3.6 - 2,800	9 - 800	A
304	50	3,000	3.6 - 2,500	9 - 700	A
305	60	3,000	3.6 - 2,800	9 - 800	A
306	75	2,500	3.6 - 2,900	9 - 800	A
307	100	2,500	3.4 - 2,400	13 - 700	A
309	130	2,500	3.4 - 2,400	13 - 700	B
310	150	2,000	4 - 2,500	40 - 900	B
311	180	2,000	4 - 2,100	18 - 800	B
313	200	2,000	4 - 2,200	18 - 800	B
314	225	2,000	4 - 1,800	50 - 600	B
315	250	1,500	4 - 1,800	70 - 900	B
316	270	1,500	4.4 - 1,200	50 - 600	B
317	300	1,000	4 - 1,900	70 - 900	B
318	340	1,000	4.4 - 1,100	200 - 700	B
319	380	500	4.8 - 1,400	300 - 800	B
321	450	300	4.4 - 1,100	300 - 800	B
323	850	300	4.6 - 1,300	-	B
325	1,050	300	4.6 - 1,300	-	B

Design A • 300 - 307

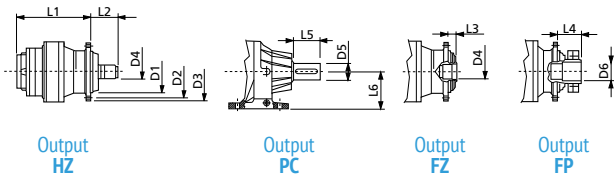

Design B • 309 - 325

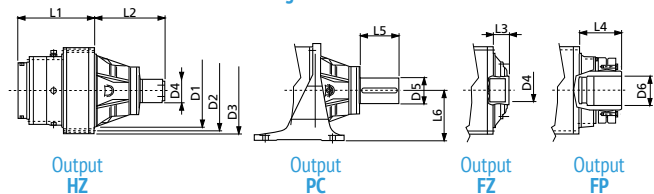

Type	D1	D2	D3	D4	D5	D6	L1 (2 stages)	L2	L3	L4	L5	L6
300	110	165	185	40x36 DIN 5482	38	42	168	61	14	50	58	100
301	110	165	185	40x36 DIN 5482	50	42	180	61	14	50	82	132
303	150	195	222	58x53 DIN 5482	60	75	200	83	15	85	105	160
304	150	195	222	58x53 DIN 5482	60	75	212	83	15	85	105	160
305	150	195	222	58x53 DIN 5482	60	75	230	83	15	85	105	160
306	200	250	280	70x64 DIN 5482	80	90	260	130	40	115	130	180
307	230	295	325	80x74 DIN 5482	90	100	300	162	36	120	170	200
309	278	314	348	80x74 DIN 5482	100	120	215	231	82	245	165	225
310	340	370	400	100x94 DIN 5482	110	130	245	290	95	290	210	250
311	358	390	428	100x94 DIN 5482	120	135	250	320	88	190	210	280
313	385	415	445	120x3 DIN 5480	140	145	310	357	81	235	200	280
314	460	503	542	150x5 DIN 5480	160	180	370	429	98	260	240	315
315	460	503	542	150x5 DIN 5480	160	180	390	429	98	260	240	315
316	580	625	670	170x5 DIN 5480	180	180	430	275	145	265	260	400
317	560	635	695	200x5 DIN 5480	200	260	470	352	152	318	260	415
318	700	750	800	220x5 DIN 5480	250	220	550	340	155	305	330	500
319	800	880	940	260x5 DIN 5480	280	350	570	470	210	440	380	550
321	940	1020	1100	300x8 DIN 5480	340	390	595	500	250	440	540	650
323	1100	1220	1300	400x8 DIN 5480	-	410	666	-	375	520	-	-
325	1260	1380	1460	450x8 DIN 5480	-	450	698	-	400	590	-	-

# Helical drives (bevel or parallel shaft)

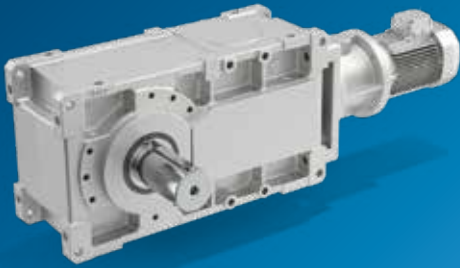

## HDP/HDO Series

When high torque, robustness, reliability and long-operating life are required, Bonfiglioli's HDx Series is the best possible option. Thanks to high-quality materials and an optimized design, the HD Series can operate in the harshest environments, as well as in explosive atmospheres, with low maintenance costs and long service intervals. The output shaft can be chosen both in the parallel (HDP) or right angle (HDO) configuration to always ensure minimization of mounting space. The HDx Series can also be fully customized thanks to an extremely broad portfolio of options and accessories. It thus meets most requirements of a large number of applications.



### Gear ratios

- 5.6 ... 500

### Main options

- Fan cooling, cooling coil, oil heater
- External cooling unit
- Backstop
- Forced lubrication
- Temperature and oil level sensors
- Drywell
- Taconite seals
- ATEX certification for explosive environments

### Key benefits

- Highly transmissible power
- Robustness
- Mounting flexibility
- Reliability
- Usable in explosive environments

### Key features

- Spheroidal cast iron housing
- I/O shaft planarity and gearbox symmetry
- Wide range of options and accessories
- High design standards
- Atex - gearbox for explosive environments 2G/2D

### Torque (Nm)

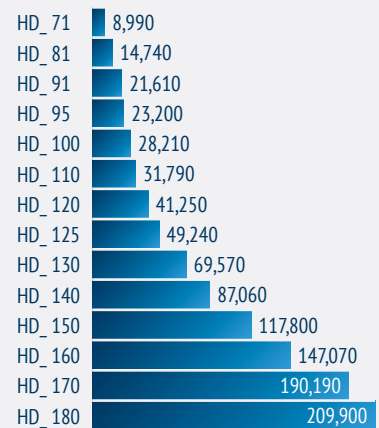



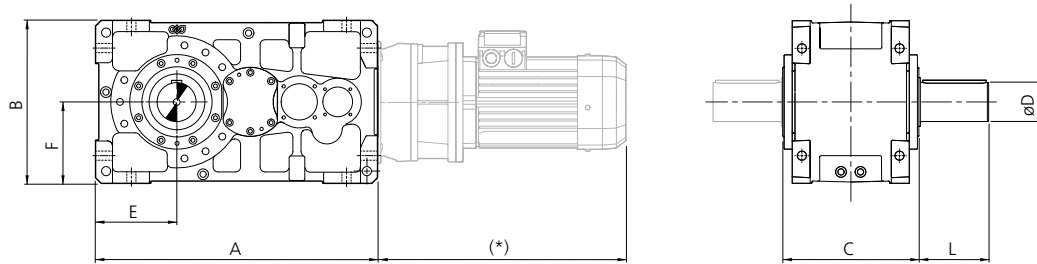

Size	A	B	C	L	D	E	F
71	585	350	265	170	80	155	175
81	700	400	320	210	100	185	200
91	830	450	360	210	110	225	225
95	865	500	360	210	120	250	250
100	950	540	370	210	120	270	270
110	950	540	370	210	120	255	270
120	1080	600	400	250	140	300	300
125	1160	680	400	300	160	340	340
130	1290	760	500	300	170	355	380
140	1355	760	500	300	180	380	380
150	1509	840	600	350	210	420	440
160	1550	880	600	350	210	440	440
170	1615	950	640	330	250	475	500
180	1680	985	640	330	250	525	500

# Global Presence



With a broad and extensive presence in 22 countries and 5 continents, Bonfiglioli is one of the international market leaders. Our organization makes the most of geographic proximity to offer complete solutions combining efficiency and competence.



3700  
EMPLOYEES



20  
BRANCHES



14  
PLANTS



550  
DISTRIBUTORS



80  
COUNTRIES

## We Are a Global Company

Thanks to an international network of sales branches and closely interconnecting production plants, we can guarantee the same high standards of Bonfiglioli quality anywhere at any given time. Aware that our direct presence in local markets is the key to long-lasting success, our family includes 20 sales branches, 14 production plants and more than 500 distributors around the world.

**Our organization is always close by, offering complete and efficient solutions and supporting our customers with dedicated services, such as co-engineering or after-sales assistance.**



# Bonfiglioli Worldwide Locations

## Australia

### **Bonfiglioli Transmission (Aust.) Pty Ltd**

2, Cox Place Glendenning NSW 2761  
Locked Bag 1000 Plumpton NSW 2761  
Tel. +61 2 8811 8000

## Brazil

### **Bonfiglioli Redutores do Brasil Ltda**

Travessa Cláudio Armando 171 - Bloco 3 - CEP 09861-730  
Bairro Assunção - São Bernardo do Campo - São Paulo  
Tel. +55 11 4344 2322

## China

### **Bonfiglioli Drives (Shanghai) Co. Ltd.**

#68, Hui-Lian Road, QingPu District,  
201707 Shanghai  
Tel. +86 21 6700 2000

## France

### **Bonfiglioli Transmission s.a.**

14 Rue Eugène Pottier  
Zone Industrielle de Moimont II - 95670 Marly la Ville  
Tel. +33 1 34474510

## Germany

### **Bonfiglioli Deutschland GmbH**

Sperberweg 12 - 41468 Neuss  
Tel. +49 0 2131 2988 0

### **Bonfiglioli Vectron GmbH**

Europark Fichtenhain B6 - 47807 Krefeld  
Tel. +49 0 2151 8396 0

### **O&K Antriebstechnik GmbH**

Ruhrallee 8-12 - 45525 Hattingen  
Tel. +49 0 2324 2050 1

## India

### **Bonfiglioli Transmission Pvt Ltd**

Plot No. AC7-AC11, SIDCO Industrial Estate,  
Thirumudivakkam - 600 044 Chennai  
Tel. +91 44 2478 1035

### **Industrial**

Survey No. 528, Porambakkam High Road,  
Mannur Village, Sriperambudur Taluk - 602 105 Chennai  
Tel. +91 44 6710 3800  
Plot No. A-95, Phase IV, MIDC Chakan, Village Nighoje  
Pune, Maharashtra - 410 501

## Italy

### **Bonfiglioli Riduttori S.p.A.**

#### **Headquarters**

Via Giovanni XXIII, 7/A - 40012 Lippo di Calderara di Reno  
Tel. +39 051 647 3111

#### **Mobile, Wind**

Via Enrico Mattei, 12 Z.I. Villa Selva - 47100 Forlì  
Tel. +39 0543 789111

#### **Industrial**

Via Bazzane, 33/A - 40012 Calderara di Reno  
Tel. +39 051 6473111  
Via Trinità, 1 - 41058 Vignola  
Tel. +39 059 768511

### **Bonfiglioli Italia S.p.A**

Via Sandro Pertini lotto 7b - 20080 Carpiano  
Tel. +39 02 985081

### **Bonfiglioli Mechatronic Research S.p.A**

Via F. Zeni 8 - 38068 Rovereto  
Tel. +39 0464 443435/36

## New Zealand

### **Bonfiglioli Transmission (Aust.) Pty Ltd**

88 Hastie Avenue, Mangere Bridge, 2022 Auckland  
PO Box 11795, Ellerslie  
Tel. +64 09 634 6441

## Singapore

### **Bonfiglioli South East Asia Pte Ltd**

8 Boon Lay Way, #04-09,  
8@ Tadehub 21, Singapore 609964  
Tel. +65 6268 9869

## Slovakia

### **Bonfiglioli Slovakia s.r.o.**

Robotnícka 2129  
Považská Bystrica, 01701 Slovakia  
Tel. +421 42 430 75 64

## South Africa

### **Bonfiglioli South Africa Pty Ltd**

55 Galaxy Avenue, Linbro Business Park - Sandton  
Tel. +27 11 608 2030

## Spain

### **Tecnotrans Bonfiglioli, S.A.**

Pol. Ind. Zona Franca, Sector C, Calle F, nº 6  
08040 Barcelona  
Tel. +34 93 447 84 00

## Turkey

### **Bonfiglioli Turkey Jsc**

Atatürk Organize Sanayi Bölgesi, 10007 Sk. No. 30  
Atatürk Organize Sanayi Bölgesi, 35620 Çiğli - Izmir  
Tel. +90 0 232 328 22 77

## United Kingdom

### **Bonfiglioli UK Ltd.**

Unit 1 Calver Quay, Calver Road, Winwick  
Warrington, Cheshire - WA2 8UD  
Tel. +44 1925 852667

## USA

### **Bonfiglioli USA Inc.**

3541 Hargrave Drive  
Hebron, Kentucky 41048  
Tel. +1 859 334 3333

## Vietnam

### **Bonfiglioli Vietnam Ltd**

Lot C-9D-CN My Phuoc Industrial Park 3  
Ben Cat - Binh Duong Province  
Tel. +84 650 3577411



We have a relentless commitment to excellence, innovation & sustainability. Our team creates, distributes and services world-class power transmission & drive solutions to keep the world in motion.

#### **HEADQUARTERS**

Bonfiglioli Riduttori S.p.A.  
Via Giovanni XXIII, 7/A  
40012 Lippo di Calderara di Reno  
Bologna (Italy)  
tel: +39 051 647 3111  
fax: +39 051 647 3126  
[bonfiglioli@bonfiglioli.com](mailto:bonfiglioli@bonfiglioli.com)  
[www.bonfiglioli.com](http://www.bonfiglioli.com)

